

P-51D MUSTANG



INSTRUCTION MANUAL

WARRANTY

Tower Hobbies® guarantees this kit to be free from defects in both material and workmanship at the date of purchase. This warranty does not cover any component parts damaged by use or modification. In no case shall Tower Hobbies' liability exceed the original cost of the purchased kit. Further, Tower Hobbies reserves the right to change or modify this warranty without notice.

In that Tower Hobbies has no control over the final assembly or material used for final assembly, no liability shall be assumed nor accepted for any damage resulting from the use by the user of the final user-assembled product. By the act of using the user-assembled product, the user accepts all resulting liability.

If the buyer is not prepared to accept the liability associated with the use of this product, the buyer is advised to return this kit immediately in new and unused condition to the place of purchase.

To make a warranty claim send the defective part or item to Hobby Services at the address below:

Hobby Services • 3002 N. Apollo Dr. Suite 1 • Champaign IL 61822 • USA

Include a letter stating your name, return shipping address, as much contact information as possible (daytime telephone number, fax number, e-mail address), a detailed description of the problem and a photocopy of the purchase receipt. Upon receipt of the package the problem will be evaluated as quickly as possible.

LENGTH ◀

34 in [864 mm]

WINGSPAN ◀

40 in [1016 mm]

WING AREA ◀

303 in² [15.2 dm²]

WEIGHT ◀

29.7–32 oz [840–905 g]

WING LOADING ◀

14.1–15.2 oz/ft² [43–46 g/dm²]

RADIO ◀

4-Channel minimum required

**READ THROUGH THIS MANUAL
BEFORE STARTING CONSTRUCTION.
IT CONTAINS IMPORTANT INSTRUCTIONS
AND WARNINGS CONCERNING THE
ASSEMBLY AND USE OF THIS MODEL.**

TOWER HOBBIES

Champaign, Illinois
(217) 398-8970 ext. 5

TOWA2000 Mnl 1.1
©2010 Tower Hobbies®

TOWER HOBBIES®

TABLE OF CONTENTS

AMA	2
SAFETY PRECAUTIONS	2
REQUIRED ITEMS	3
Optional Tools and Supplies	3
Battery & Charger Recommendations	3
ORDERING REPLACEMENT PARTS	3
KIT INSPECTION	3
KIT CONTENTS	4
ASSEMBLE THE WING	4
ASSEMBLE THE FUSELAGE	5
RADIO SETUP	6
INSTALL THE LANDING GEAR (Optional)	7
INSTALL THE PROPELLER AND SPINNER	8
GET THE MODEL READY TO FLY	8
Check the Controls & Control Direction	8
Check the Control Throws	9
Balance the Model (C.G.)	9
APPLY THE DECALS	10
PREFLIGHT	10
Identify Your Model	10
Charge the Battery	10
MOTOR SAFETY PRECAUTIONS	10
LITHIUM BATTERY HANDLING & USAGE	11
FLYING THE P-51 MUSTANG	11
Find a Suitable Flying Site	11
Perform a Range Check	11
Monitor Your Flight Time	11
Take Off	11
ROG Take Off	12
Flying	12
Landing	12
AFTER EACH FLIGHT	12
REPAIRING YOUR MODEL	12

AMA

We urge you to join the AMA (Academy of Model Aeronautics) and a local R/C club. The AMA is the governing body of model aviation and membership is required to fly at AMA clubs. Though joining the AMA provides many benefits, one of the primary reasons to join is liability protection. Coverage is not limited to flying at contests or on the club field. It even applies to flying at public demonstrations and air shows. Failure to comply with the Safety Code (excerpts printed in the back of the manual) may endanger insurance coverage. Additionally, training programs and instructors are available at AMA club sites to help you get started the right way. There are over 2,500 AMA chartered clubs across the country. Contact the AMA at the address or toll-free phone number below:

Academy of Model Aeronautics

5151 East Memorial Drive
Muncie, IN 47302-9252

Ph. (800) 435-9262
Fx. (765) 741-0057



Or via the Internet at: <http://www.modelaircraft.org>

IMPORTANT: Two of the most important things you can do to preserve the radio controlled aircraft hobby are to avoid flying near full-scale aircraft and avoid flying near or over groups of people.

SAFETY PRECAUTIONS

PROTECT YOUR MODEL, YOURSELF & OTHERS.....FOLLOW THESE IMPORTANT SAFETY PRECAUTIONS

1. Your Mustang should not be considered a toy, but rather a sophisticated, working model that functions very much like a full-size airplane. Because of its performance capabilities, this model, if not assembled and operated correctly, could possibly cause injury to yourself or spectators and damage to property.
2. You must assemble the model **according to the instructions**. Do not alter or modify the model, as doing so may result in an unsafe or unflyable model. In a few cases the instructions may differ slightly from the photos. In those instances the written instructions should be considered as correct.
3. You must take time to **build straight, true and strong**.
4. You must use an R/C radio system that is in first-class condition, and a correctly sized motor and components throughout the building process.
5. You must correctly install all R/C and other components so that the model operates correctly on the ground and in the air.
6. You must check the operation of the model before **every** flight to insure that all equipment is operating and that the model has remained structurally sound. Be sure to check clevises or other connectors often and replace them if they show any signs of wear or fatigue.
7. If you are not an experienced pilot or have not flown this type of model before, we recommend that you get the assistance of an experienced pilot in your R/C club for your first flights. If you're not a member of a club, your local hobby shop has information about clubs in your area whose membership includes experienced pilots.
8. While this kit has been flight tested to exceed normal use, if the plane will be used for extremely high stress flying, such as racing, or if an engine larger than one in the recommended range is used, the modeler is responsible for taking steps to reinforce the high stress points and/or substituting hardware more suitable for the increased stress.

We, as the kit manufacturer, provide you with a top quality, thoroughly tested kit and instructions, but ultimately the quality and flyability of your finished model depends on how you build it; therefore, we cannot in any way guarantee the performance of your completed model, and no representations are expressed or implied as to the performance or safety of your completed model.

ORDERING REPLACEMENT PARTS

Replacement parts are available from Tower Hobbies for your P-51. Our order assistance representatives are ready to answer your questions or to place your order. Call us at (800) 637-6050.

REMEMBER: Take your time and follow the instructions to end up with a well-built model that is straight and true.

REQUIRED ITEMS

- Screwdrivers – Phillips & Flat
- Scissors
- Pliers, regular & needle-nose
- Felt-Tipped Pen (TOPQ2510)

Optional Tools and Supplies

- PRO™ Threadlocker (GPMR6060)
- 1/2 oz. [15g] Medium Pro CA+ (GPMR6007)
- CA applicator tips (HCAR3780)
- 2 oz. [60g] Foam Safe CA Activator (GPMR6035)
- CA debonder (GPMR6039)
- #11 Hobby knife w/ 5 blades (EXLR9018)
- #11 blades (5-pack, EXLR0011)
- Masking tape
- Great Planes Stick-on lead weights (GPMQ4485)
- Great Planes 4-Step Prop Reamer, standard (GPMQ5005)
- 1/4" [6.4mm] drill bit

Battery & Charger Recommendations

The following batteries and chargers are recommended for this model.

Batteries

- Flyzone™ 1800mAh 11.1V LiPo Battery (HCAA3840)
- SuperTigre® 1800mAh 11.1V 15C LiPo Battery (SUPP1050)
- SuperTigre 2100mAh 11.1V 15C LiPo Battery (SUPP1060)

Chargers

- Great Planes ElectriFly™ Triton EQ™ AC/DC Charger (GPMM3155)

OR

- Great Planes® ElectriFly PolyCharge4™ LiPo battery charger (GPMM3015)

WITH

- Great Planes ElectriFly Equinox™ LiPo cell balancer (GPMM3160)

REPLACEMENT PARTS LIST

Order Number	Description
TOWA6070	Wing Set
TOWA6071	Fuselage
TOWA6072	Horizontal Stabilizer Set
TOWA6073	Cowl
TOWA6074	Hatch
TOWA6075	Landing Gear Set
TOWA6076	Decals
TOWM5500	Servo
TOWA6077	Wing Joiner Tube Set
TOWA6078	Tail Wheel Set
TOWA6079	Belly Scoop
TOWA6080	Nylon Wing bolt 2 pcs.
TOWA6081	Spinner
TOWG2000	Motor

KIT INSPECTION

Before assembly, match the parts in the photo on page 4 with the parts in the kit. Check off each part as they are located. If any parts are missing or damaged, consult **Tower Hobbies Order Assistance**. (See phone numbers below.)

Note: All parts are one per kit unless otherwise stated.

Tower Hobbies

P.O. Box 9078
Champaign, IL 61826-9078

Toll Free Orders Only 800 637-4989
Toll Free Order Assistance . . . 800 637-6050
Non-Toll Free Ordering 217 398-3636
Fax Ordering 217 356-6608
Toll Free Fax Ordering 800 637-7303

REQUIRED ITEMS



KIT CONTENTS

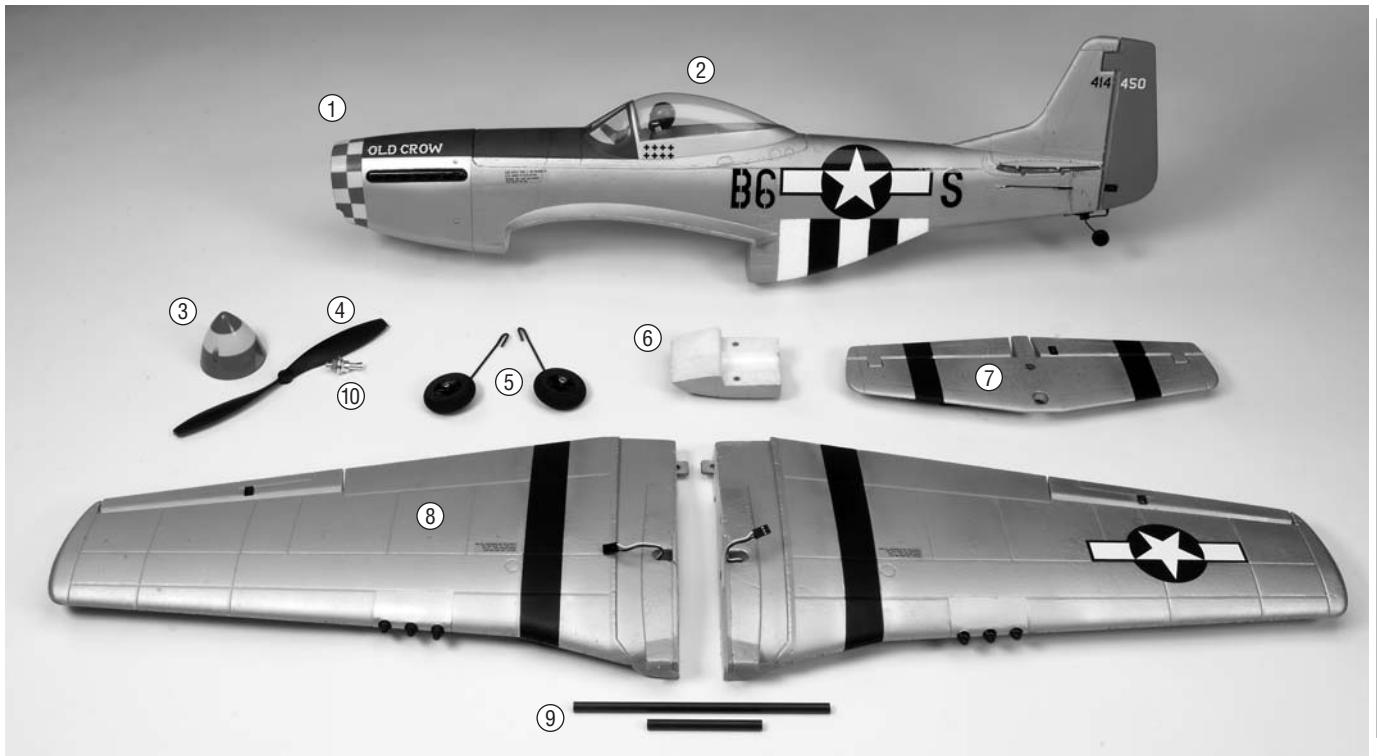

- | | | |
|-----------------------|----------------------|------------------|
| 1. Fuselage and Motor | 5. Main Landing Gear | 9. Wing Tubes |
| 2. Canopy / Hatch | 6. Belly Scoop | 10. Prop Adapter |
| 3. Spinner | 7. Horizontal Tail | |
| 4. Prop | 8. Wings | |

ASSEMBLE THE WING

- ❑ **1.** Read the **Lithium Battery Handling and Usage** section on page 11 of this manual. Charge the battery pack following the instructions that came with your charger.
- ❑ **2.** Remove all of the components from the plastic packaging and lay them out on your work surface.

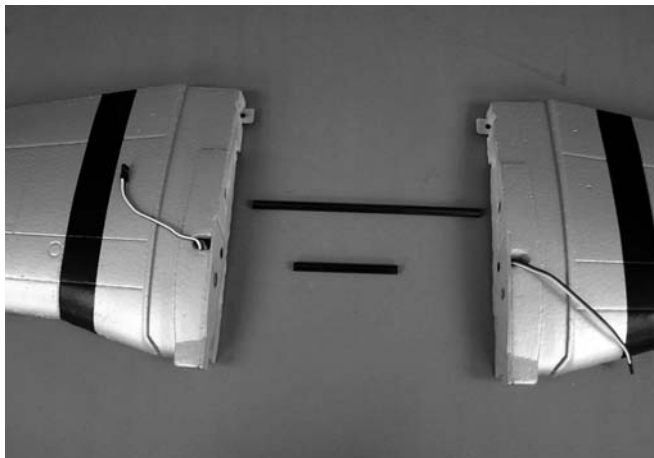

- ❑ **3.** Locate both halves of the wing along with the long and short tubes.

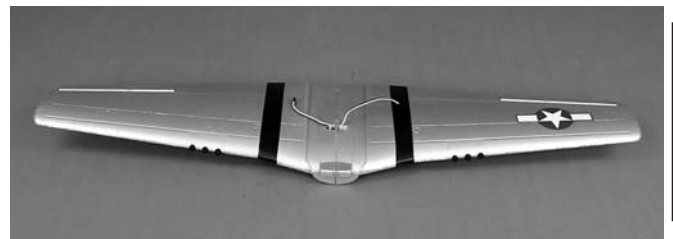
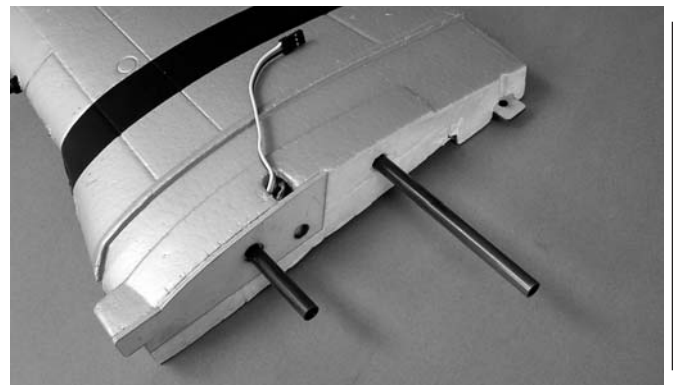

- ❑ **4.** Insert the short tube into the forward-most hole in the wing, and then insert the long tube into the rearward most hole. Slide the other wing half onto the tubes until the wing halves fit tight against each other.

That completes the wing assembly. Set the wing aside and begin the fuselage assembly.

ASSEMBLE THE FUSELAGE

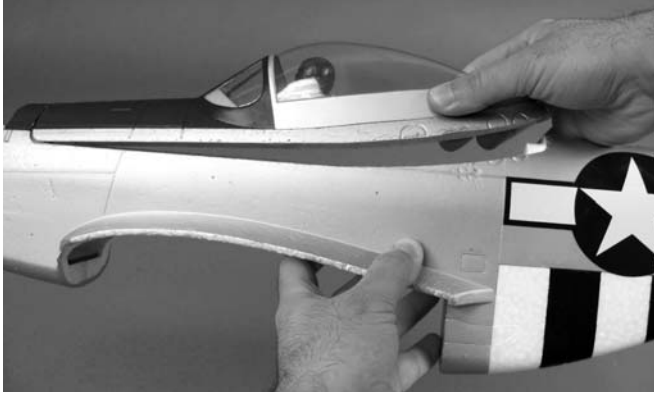

❑ **1.** Remove the battery hatch. This is held on by three small magnets under the base of the canopy and a molded tab at the front edge. To remove the hatch, pull up the rear of the hatch.

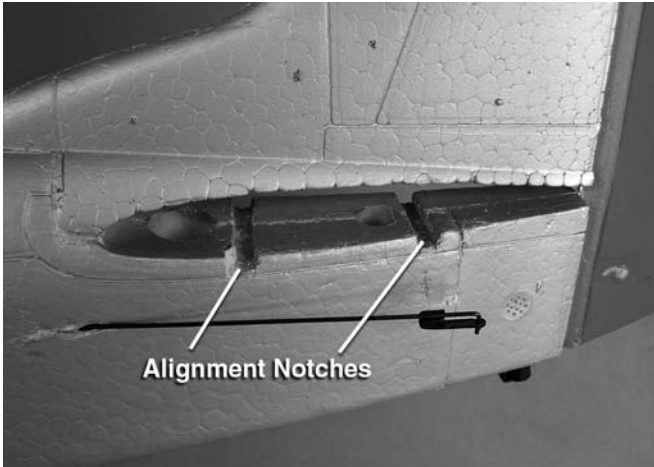

❑ **2.** At the back of the fuselage you will see the opening for the stabilizer. Look closely and you will see alignment notches that help locate the stab position.

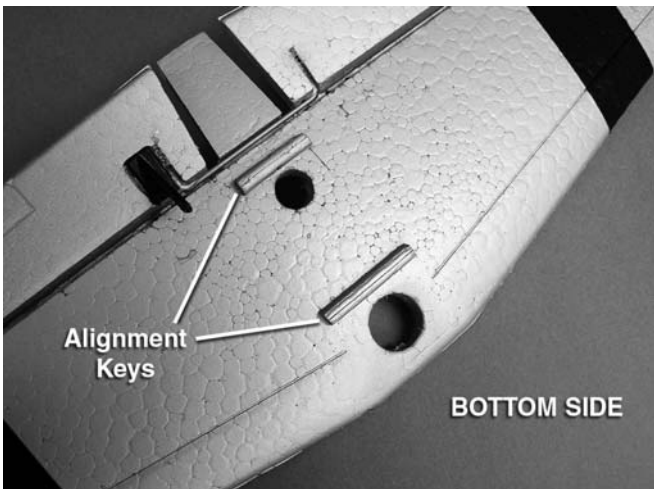

❑ **3.** On the bottom of the stabilizer you will find the raised alignment keys. These match up with the alignment notches.

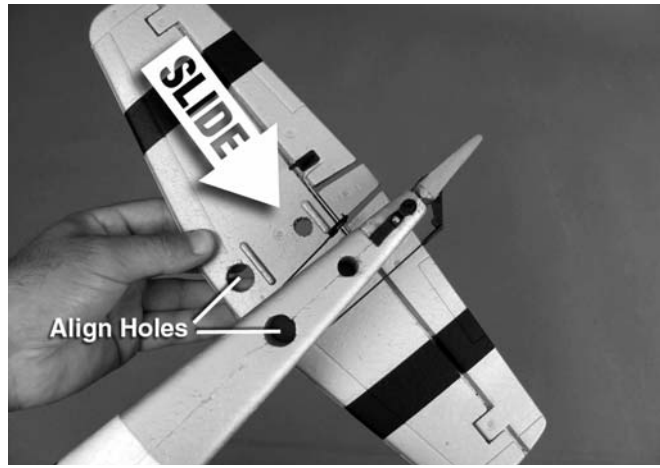

❑ **4.** Slide the stabilizer into the opening in the fuselage. When you install the stabilizer, slide the right side of the stabilizer into the left side of the fuselage. Be sure to key the stab to the slots in the fuselage. Position the stab so that it is centered and the holes in the bottom of the fuselage are aligned with the holes in the stabilizer.

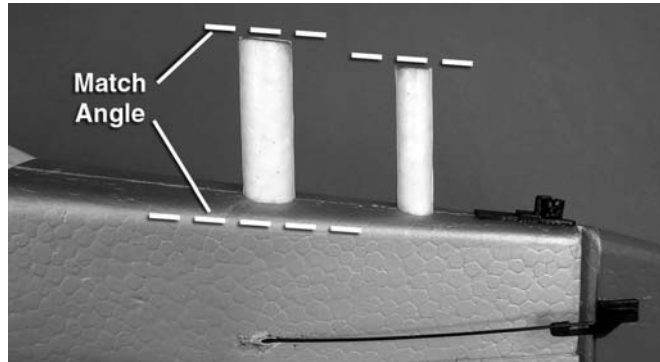

❑ **5.** Partially install the two foam plugs into the holes in the bottom of the fuselage. When you do this be sure the painted end of the plug is outside of the fuselage. These two plugs lock the stab to the fuselage. Once they are installed, the tail cannot be removed without risk of breaking them, so be sure you follow these instructions carefully. You will notice that each of the plugs has an end that is angled. When the plug is positioned properly the angle will be in line with the bottom of the fuselage.

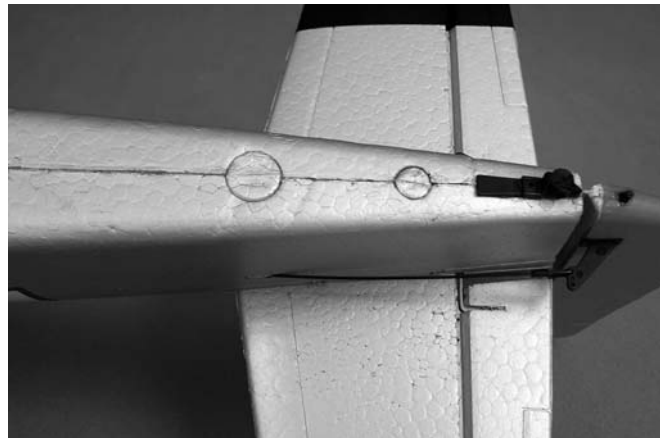

❑ **6.** When you are satisfied that you have the plugs positioned properly, insert them into the fuselage and through the stabilizer, locking the stabilizer in place.



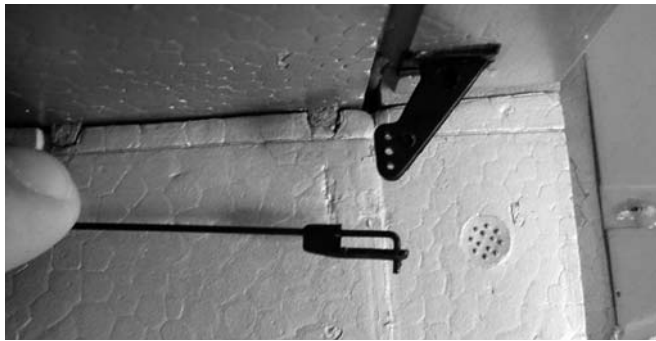

❑ **7.** Remove the black nylon Faslink from the end of the elevator pushrod by rotating the Faslink until it unsnaps from the long part of the pushrod and rotates around the L-bend. Install the pushrod wire into the outermost hole in the elevator control horn and secure it with the Faslink as shown.

RADIO SETUP

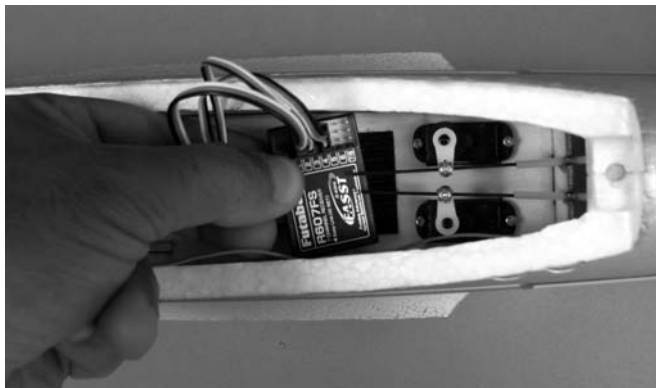

❑ **1.** Cut a 1" [25.4mm] piece of hook and loop material and stick the loop side (fuzzy side) to the back of your receiver. Stick the hook side to the battery tray just ahead of the elevator and rudder servos. Plug the included Y-connector into the aileron channel of the receiver. Plug the rudder and elevator servo leads and the ESC signal lead into the receiver. Install the receiver in the model and tape the receiver antennas in position as recommended by the radio manufacturer. Note: If you have a 72MHz radio system, poke a hole in the fuselage side and route the antenna out of the fuselage.

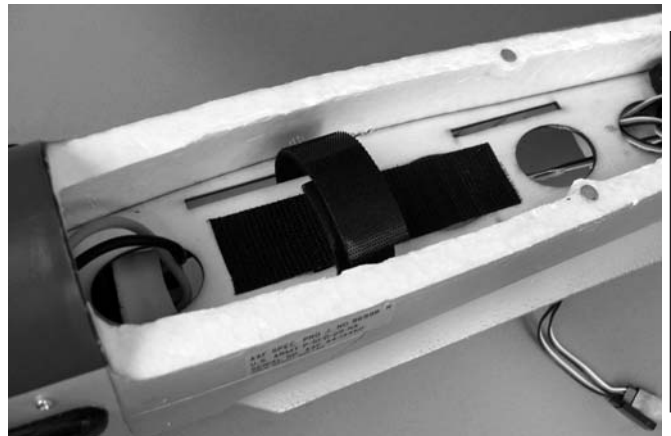

❑ **2.** Separate the hook side from the loop side of the remaining adhesive-backed hook and loop material. Stick the hook side to the battery tray and the loop side to the back of your battery pack. To prepare your other battery packs, you may purchase more Great Planes hook and loop material (GPMQ4480) from Tower Hobbies.

❑ **3.** From the bottom of the battery tray, route the hook and loop battery strap through the slots in the tray.



❑ **4.** Route the aileron servo lead Y-connector through the equipment tray. Connect the aileron servo leads to the Y-connector.

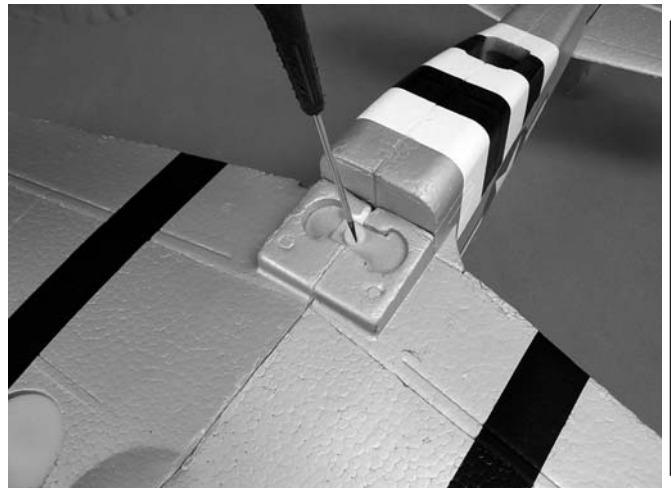

❑ **5.** Fit the wing to the fuselage and secure it with a 5mm x 60mm nylon wing bolt.

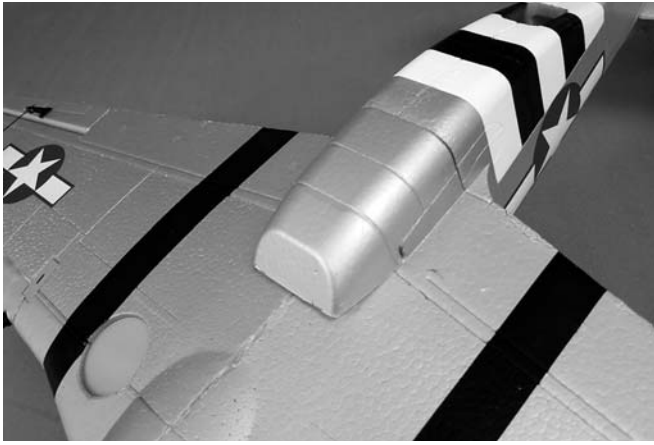

❑ **6.** Fit the radiator air scoop to the belly over the wing bolt. The magnets located in the scoop and fuselage hold it in place.

❑ **7.** Using your radio, center the elevator and rudder servos. Make sure that the elevator and rudder servo arms are 90° to the servo case when they are centered. If they are not centered, remove the servo arm retaining screw and reposition the arm on the splined shaft. Reinstall the servo arm and the retaining screw.

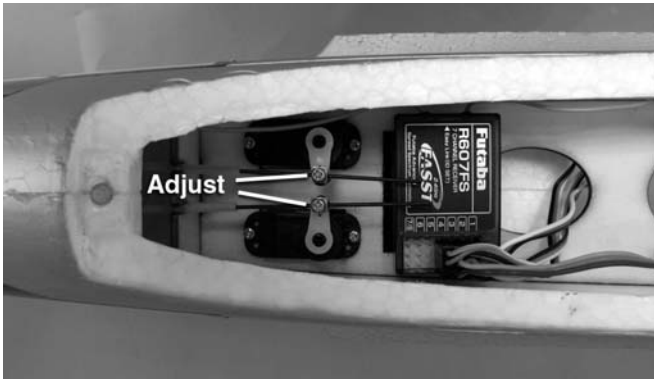

❑ **8.** With the servos centered, check to make sure that the control surfaces are centered. If they need to be adjusted, loosen the locking screw on the pushrod connector and adjust the flight control until it is centered. When you are satisfied, tighten the locking screw to hold the pushrod wires in position. Use a drop of thread locking compound on the locking screw threads for added security.



❑ **9.** Clip off the excess pushrod wire as shown, so that it doesn't interfere with the receiver when the servos move.

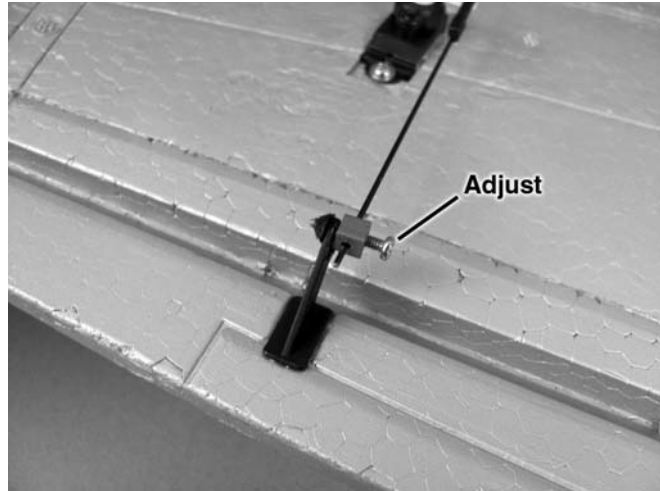

❑ **10.** Using your radio, center the aileron servos. Check to see that the ailerons are also centered. If they need adjustment, loosen the locking screw and adjust the ailerons until they are centered at zero deflection. Tighten the set screw of the screw lock pushrod connector.

INSTALL THE LANDING GEAR (Optional)

This airplane is supplied with landing gear but this should only be used if you have an asphalt or concrete runway. Any length of grass will be too much resistance for the wheels to roll on. Landing gear is not necessary for take off or landing. The airplane is easily hand launched and lands very well on its belly in grass.



❑ **1.** Install the main landing gear legs by fitting them into the slots in the bottom of the wing so that the wheel faces inboard.



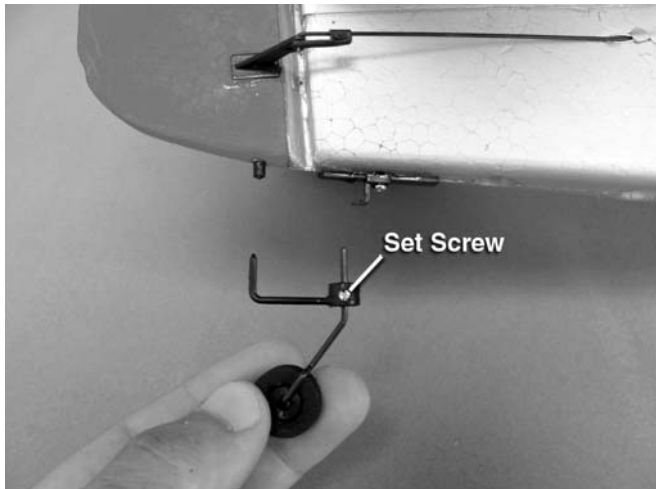

❑ **2.** Assemble the tailwheel as shown. Screw the set screw into the tailwheel guide. Slide the tailwheel guide onto the tailwheel post and tighten the set screw against the flat spot on the tailwheel post.

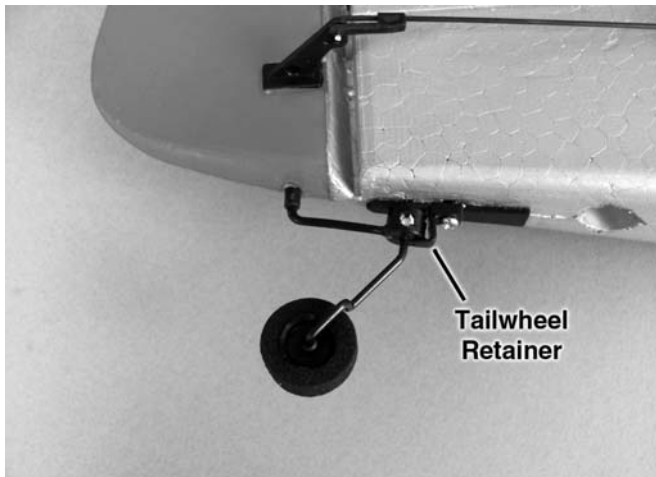

❑ **3.** Remove the tailwheel retainer. Install the tailwheel assembly to the fuselage and the tailwheel guide into the hole in the bottom of the rudder. Reinstall the tailwheel retainer.

INSTALL THE PROPELLER AND SPINNER

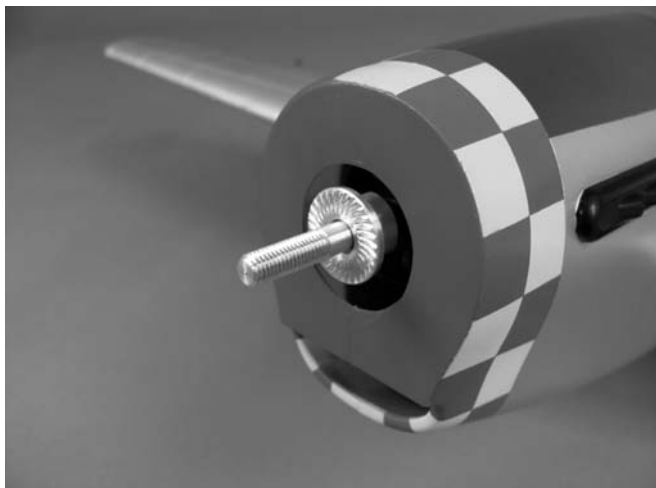

❑ **1.** Remove the prop nut and prop washer from the prop adapter. Slide the prop adapter onto the motor shaft as shown.

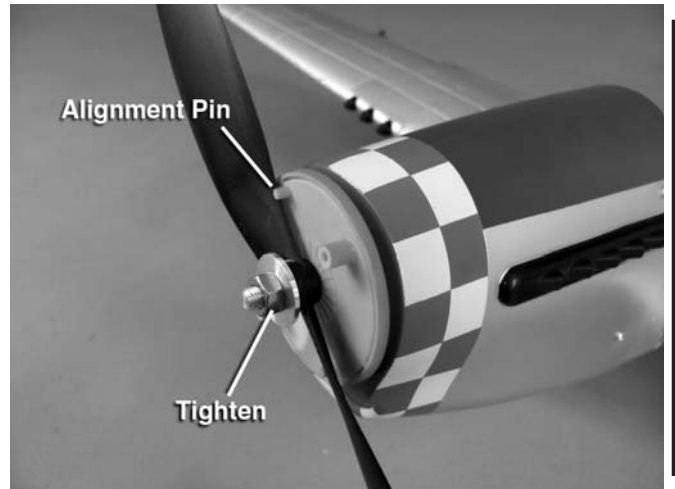

❑ **2.** Fit the spinner backplate to the prop adapter. Fit the propeller, prop washer, and prop nut. Position the propeller so that the trailing edge of each blade touches the alignment pin. Tighten the prop nut.

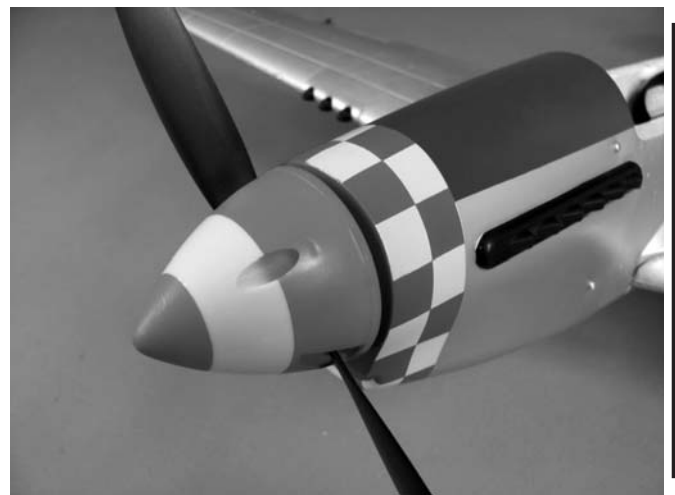

❑ **3.** Install the spinner using the two screws included in the spinner parts bag.

GET THE MODEL READY TO FLY

Check the Controls & Control Direction

WARNING: Once the battery is connected to the ESC, stay clear of the propeller! Always stay behind the propeller!

❑ **1.** Turn on the transmitter, center the trims, and move the throttle stick all the way down. Attach a charged battery.

❑ **2.** With the transmitter and receiver still on, check to make sure that all of the control surfaces are correctly centered so that they are at zero deflection. Check to see that the locking screws on the pushrod connectors are tight and that the servo arm locking screws are installed. Make sure that the nylon Faslinks are also installed properly and are holding the pushrods securely.

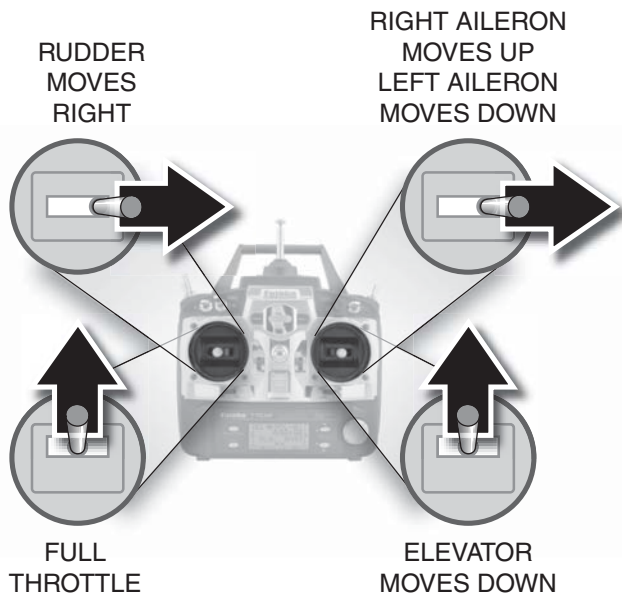

❑ **3.** Make certain that the control surfaces and the throttle respond in the correct direction as shown in the diagram. If any of the controls respond in the wrong direction, use the servo reversing in the transmitter to reverse the servos connected to those controls. Be certain the control surfaces have remained centered. Adjust if necessary.

Check the Control Throws

The control throws are limited by the travel of the servos and the mechanical set up of the pushrods. You can change the control throw using the end-points or ATV feature of your radio, or you can change the mechanical linkage to increase or decrease the amount of control movement in relation to the amount of servo movement. Keep in mind that changing the throws mechanically is preferred to changing them using your radio's end-point adjustment. End points should be used to "fine-tune" to get the proper throws.

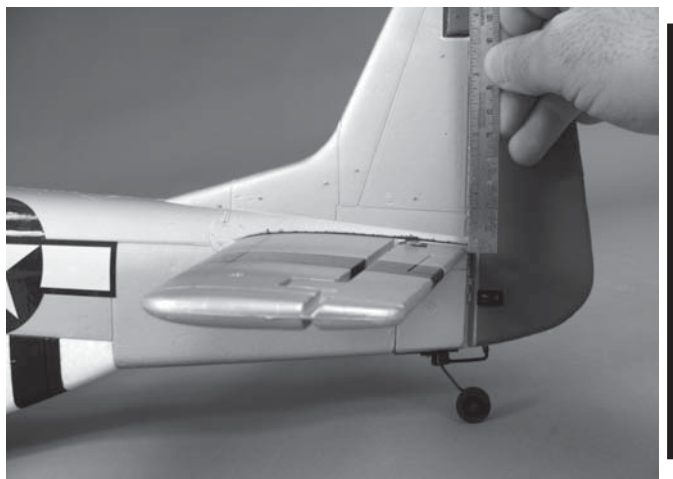

Hold a ruler up to the control surface while it is at zero throw (neutral). Move the control to the limit and measure the amount of linear control throw. If your radio does not have dual rates, we recommend setting the throws at the HIGH rate setting. NOTE: The throws are measured at the widest part of the elevators, rudder and ailerons.

If the control throws are too high, you can move the pushrod connectors on the servo arms inward (toward the output shaft) to decrease total travel.

These are the recommended control surface throws:

	HIGH RATE		LOW RATE	
	Up	Down	Up	Down
ELEVATOR	5/16" [8 mm] 15°	5/16" [8 mm] 15°	1/4" [6 mm] 12°	1/4" [6 mm] 12°
	Right	Left	Right	Left
RUDDER	3/4" [19 mm] 21°	3/4" [19 mm] 21°	1/2" [13 mm] 14°	1/2" [13 mm] 14°
	Up	Down	Up	Down
AILERONS	1/2" [13 mm] 23°	1/2" [13 mm] 23°	3/8" [10 mm] 18°	3/8" [10 mm] 18°

Balance the Model (C.G.)

❑ **1.** At this stage the model should be in ready-to-fly condition with all of the systems in place including the motor, propeller, spinner, radio system, battery, battery hatch, and belly scoop. Place the battery in the battery compartment but do not connect it. **Note:** The landing gear will have a slight effect on the C.G. position.

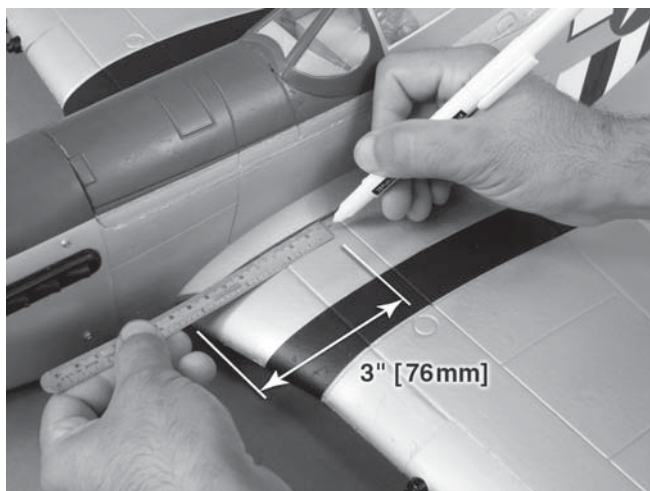

❑ **2.** Use a felt-tip pen or 1/8" [3mm]-wide tape to accurately mark the C.G. on the top of the wing on both sides of the fuselage. The C.G. is located 3" [76mm] back from the leading edge of the wing at the wing root where the wing meets the fuselage.





This is where your model should balance for the first flights. Later, you may wish to experiment by shifting the C.G. up to 1/4" [6mm] forward or 1/4" [6mm] back to change the flying characteristics. Moving the C.G. forward may improve the smoothness and stability, but the model may then require more speed for takeoff and make it more difficult to slow for landing. Moving the C.G. aft makes the model more maneuverable, but could also cause it to become too difficult to control. In any case, start at the recommended balance point and do not at any time balance the model outside the specified range.



- ❑ **3.** With all parts of the model installed (ready to fly) and a battery pack in place (do not connect it), place your fingers on the marks you made and balance the model.
- ❑ **4.** If the tail drops, the model is "tail heavy" and the battery pack must be shifted forward or weight must be added to the nose to balance. If the nose drops, the model is "nose heavy" and the battery pack must be shifted aft or weight must be added to the tail to balance.
- ❑ **5.** Using a felt-tip pen, mark the position of the battery pack in the battery compartment. This will help eliminate trim changes or unwanted surprises each time that you change the battery. When using different capacity batteries, you may have to re-balance your plane and place an additional mark in the battery compartment. If you plan to fly the model with and without landing gear, make separate marks to help you know where to place the battery to balance correctly in each configuration.
- ❑ **6.** If additional weight is required, use Great Planes (GPMQ4485) "stick-on" lead. A good place to add stick-on nose weight is to the motor box under the cowl (don't attach weight to the cowl—it is not intended to support weight). Begin by placing increasing amounts of weight on the top of the cowl over the firewall until the model balances. Once you have determined the amount of weight required, it can be permanently attached by removing the cowl and installing the weight.

IMPORTANT: If you found it necessary to add any weight, recheck the C.G. after the weight has been installed.

APPLY THE DECALS



We have provided various decals to allow you some flexibility in the final appearance of your airplane. The photo shows the placement of the decals "Old Crow" but the other decals get positioned in the same place as those shown on "Old Crow". The choice is yours! Simply cut out the decals of your choosing and apply them to the fuselage.

PREFLIGHT

Identify Your Model

No matter if you fly at an AMA sanctioned R/C club site or if you fly somewhere on your own, you should always have your name, address, telephone number and AMA number on or inside your model. It is required at all AMA R/C club flying sites and AMA sanctioned flying events and simply a "good idea" even if flying somewhere else. Write this information on a strip of masking tape and place it on the inside of the battery hatch (or simply write the information directly on the battery hatch).

Charge the Battery

Be certain to refer to the instructions that accompany the charger to properly and safely charge the battery that goes in the model and powers the motor and controls.

When discharging the battery, DO NOT attempt to fully discharge the battery pack by repeatedly running the motor to the ESC's low voltage cutoff. This will drastically shorten the life of your Lithium polymer (LiPo) batteries and could cause the individual cells to become imbalanced.

MOTOR SAFETY PRECAUTIONS

Failure to follow these safety precautions may result in severe injury to yourself and others.

- Get help from an experienced pilot when learning to operate electric motors.
- Use safety glasses when operating electric motors.
- Do not operate the motor in an area of loose gravel or sand; the propeller may throw such material in your face or eyes.

- Keep your face and body, as well as all spectators, away from the plane of rotation of the propeller as you operate the motor.
- Keep these items away from the prop: loose clothing, shirt sleeves, sweat shirt strings, ties, scarves, long hair or loose objects such as pencils or screwdrivers that may fall out of shirt or jacket pockets into the prop.
- The motor will arm when the throttle is at idle and the battery is plugged in. There is no further arming sequence for this model. Use extreme caution when working around an armed power system.

LITHIUM BATTERY HANDLING AND USAGE

WARNING!! Read the entire instruction sheet included with the battery. Failure to follow all instructions could cause permanent damage to the battery and its surroundings, and cause bodily harm!

- ONLY use a LiPo approved charger.
- NEVER charge in excess of 4.20V per cell.
- ONLY charge through the “charge” lead using a cell balancing charger. NEVER charge through the “discharge” lead only.
- NEVER charge at currents greater than 1C.
- ALWAYS set charger’s output volts to match battery volts.
- ALWAYS charge in a fireproof location.
- NEVER trickle charge.
- NEVER allow battery temperature to exceed 150° F (65° C).
- NEVER disassemble or modify pack wiring in any way or puncture cells.
- NEVER discharge below 3.0V per cell.
- NEVER place on combustible materials or leave unattended during charge or discharge.
- ALWAYS KEEP OUT OF REACH OF CHILDREN.
- Always use a balance charger designed to charge LiPo batteries for charging the LiPo flight battery.
- Never leave the LiPo battery unattended while charging. If the battery becomes hot, discontinue charging.

FLYING THE P-51 MUSTANG

While the P-51 is fairly easy to fly, if you have never flown a model aircraft before, it is strongly suggested that you learn to fly with the assistance of an experienced R/C pilot.

Find a Suitable Flying Site

Find a flying site clear of buildings, trees, power lines and other obstructions. Until you know how much area will be required and have mastered flying your P-51, a site at least the size of two or three football fields should be adequate—a flying field specifically intended for R/C planes is best. Don’t fly within six miles of R/C flying fields and never fly near people—especially children who can wander unpredictably.

Perform a Range Check

As a precaution, an operational ground range test should be performed before the first flight each time out. Performing a range test is a good way to detect problems that could cause loss of control such as low batteries, defective or damaged radio components or radio interference. This usually requires an assistant and should be done at the actual flying site you will be using.

First, put the throttle stick in the low position and turn on the transmitter. Then, install the fully charged battery into the fuselage and hold it in place with the hook-and-loop strap. Connect the battery and install the hatch.

Remember, use care not to “bump” the throttle stick. Otherwise, the propeller will turn, possibly causing damage or injury.

With the antenna on the transmitter collapsed (not extended), begin walking away from the model operating the controls in a predictable pattern (for example: Up, then down elevator. Right, then left aileron. Right, then left rudder). While moving the control surfaces, also vary motor rpm. Have your assistant alert you if the controls fail to respond or if they move suddenly or erratically. You should be able to maintain control up to a distance of approximately 100’ [30m].

If the controls respond erratically or if anything else seems wrong, make certain all the servo wires are securely connected to the receiver and that the transmitter and receiver batteries are fully charged. If you cannot find a mechanical problem with the model, it is slightly possible that there is radio interference somewhere in the area. One option would be to try another range check at an alternate flying site.

After the range check, fully extend the antenna.

Monitor Your Flight Time

Monitor and limit your flight time using a timer such as the one on your wrist watch. When the batteries are getting low you will usually notice a performance drop before the ESC cuts off motor power, so when you notice the plane flying slower you should land. Often (but not always!), power can be briefly restored after the motor cuts off by holding the throttle stick all the way down for a few seconds, then moving it up again.

To avoid an unexpected dead-stick landing on your first flight, set your timer to a conservative 8 minutes. When the alarm sounds you should land your model.

When you learn how much flight time you are getting you can adjust your timer accordingly. Always be conservative so the motor won’t quit unexpectedly and you will have enough battery to land under power.

Take Off

Until you have become comfortable with flying your P-51, do not fly if the wind speed is greater than 10 mph [16 kilometers/hr].

One final check before takeoff: always double-check the flight control response to your inputs from the transmitter before every flight. Be certain the ailerons, elevator and rudder respond correctly and that none of the controls have inadvertently become reversed.

Don’t forget to fully extend the transmitter antenna.



If the surface is smooth (such as pavement or blacktop) the P-51 can take off from the ground. But most grass is probably too tall, so if flying from grass the model will have to be hand launched.

ROG Take Off

If taking off from the ground, place the model on your “runway” with the nose pointing directly into the wind—this will reduce the ground speed that must be reached and automatically provide “heading assist” making steering and takeoff easier. Slowly advance the throttle, adding rudder correction as needed to keep the model rolling straight. When the plane becomes “light” continue to apply throttle until you are at full-power—all this will happen in a few seconds. When sufficient liftoff speed has been reached, gradually apply “up” elevator allowing the model to leave the ground. Do not “yank” up on the stick—rather, be smooth and allow the plane to establish a gentle climb.

Once you have reached a safe flying speed at a comfortable altitude (approximately 50' [15m]), work the controls as necessary to establish a gentle turn away from the runway.

Flying

One thing to remember is that, when the plane is flying away from you, moving the aileron stick to the right will make the plane bank to your right. However, when the model is flying toward you, moving the aileron stick to the right will make the plane move to your left. Of course, the plane is still responding the same way, it's just that your orientation has reversed. This must be kept in mind while learning to fly (and is also a good reason to take flight lessons from an experienced pilot!).

To establish a turn, “up” elevator (pulling back on the stick) is usually required along with aileron input to get the model into a bank. To stop the turn, apply a small amount of opposite aileron.

Once you get the plane into the air and have climbed to a comfortable altitude, the first “order of business” will be to “trim” the model for straight-and-level flight. The model flies best at approximately 3/4-throttle. Adjust the trims on the transmitter to make minor control surface adjustments as necessary until the plane will fly straight without any control inputs. Often, your assistant can reach over and adjust the trims for you.

Remember to keep the model high enough to give yourself time to make corrections, but don't let it get too far away. Otherwise, it will be difficult to detect its attitude and which way it is going.

One final check before landing: see how the model will react when it's time to land and you reduce the throttle. To do this, while still at altitude, cut the motor power. The model should establish a gentle, downward glide path. This is how the model will react when it's actually time to land. Add power and climb back up to your original altitude.

Practice a few of these “climb and glides” to judge how far out you will need to be when it's time to land.

Landing

To land, fly down-wind past the landing area. Gently turn into the wind, and reduce the throttle so that the airplane initiates a descending glide path. If necessary, add power to extend the glide path to reach the runway. As the model approaches and loses altitude, gradually and proportionally add “up” elevator to control

the glide path and altitude. Continue to apply elevator until the model touches down at which time you should be holding full, or nearly full up elevator. This will cause the airplane to slow and settle to the ground.

CAUTION: If, during a rough landing, the propeller becomes jammed and cannot rotate, the battery and speed control will become very hot if you attempt to add power. Immediately move the throttle down to stop the motor. If you fail to do this, the motor, speed control and/or battery will be damaged.

AFTER EACH FLIGHT

Disconnect the battery and remove it from the airplane. Then, turn off the transmitter. Allow the battery to cool before recharging, or allow the motor to cool before installing another battery for the next flight. Inspect the airplane to make sure nothing has become loose or damaged.

REPAIRING YOUR MODEL

❑ **1.** If your model becomes damaged, it can be repaired using regular medium CA. Spare parts are available – please see the parts list earlier in this manual for more details of what is available and how to get new parts. CA debonder (GPMR6039) is available if you ever need to dissolve the CA adhesive you used to build or repair this model.



❑ **2.** If you ever need to replace the propeller, please order a Great Planes Power Flow 9×4.5 Slo-Flyer electric propeller (GPMQ6630). To use this prop, enlarge the hole in the prop hub using a 1/4" [6.4mm] drill bit or a 1/4" prop reamer. If you are using a drill bit, be very careful to drill perpendicular to the prop hub.

Have a ball! But always stay in control and fly in a safe manner.

GOOD LUCK AND GREAT FLYING!

